



## Save up to 90% on energy costs with the VS PlusHP Variable-Speed Pump<sup>2</sup>

The VS PlusHP is a high-performance, energy-efficient pump, in a mid-sized body that can save up to 90% in electrical cost savings versus single-speed pumps.

### » Ultra high-efficiency motor

Features a totally enclosed fan-cooled (TEFC) permanent magnet brushless DC motor for cooler operation and extended motor life.

### » Quiet

When used at energy-saving lower speeds, the advanced motor design of the VS PlusHP generates up to 70% less noise than single-speed pumps.

### » Digital controller included<sup>3</sup>

Two timed speeds/eight speeds total. Remotely-mounted controller provides easy access to pump controls. Reliable battery backup ensures time and settings are stored during power outages.



### » Auxiliary Circuit

Features an auxiliary circuit that can be used to control other devices such as booster pumps or salt water chlorinators without the need for an additional timeclock.

### » Additional Features

- 40% larger strainer basket than the leading competitor for greater pool owner convenience and improved efficiency when loaded with debris.
- Unions included for fast and reliable connections to 2" or 2-1/2" pipe.
- Ergonomic carry handle for easy installation.
- High-profile easy-grip handles for easier strainer basket removal.
- Compact design is ideal for tight equipment pads or replacement of older single-speed pumps.

### » Complies with Appliance Efficiency Standards

(CEC Title 20 & ANSI<sup>®</sup>/APSP-15) and qualifies for utility rebates, where offered. ENERGY STAR<sup>®</sup> certified.

#### Zodiac Pool Systems, Inc.

2620 Commerce Way, Vista, CA 92081  
1.800.822.7933 | www.ZodiacPoolSystems.com

#### Zodiac Pool Systems Canada, Inc.

2115 South Service Road West, Unit #3, Oakville, ON L6L 5W2  
1.888.647.4004 | www.ZodiacPoolSystems.ca

#### DIMENSIONS

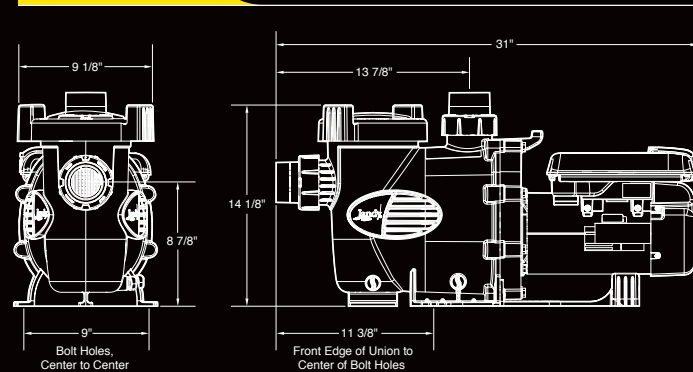

#### SPECIFICATIONS

Model No.	Total Horsepower	Voltage	Max. Watts	Power Requirements <sup>4</sup>	Carton Weight	Overall Length
VSPHP270JEP	2.70	230VAC	2,400 W	Min. 15A/14AWG	50 lbs	30%*
VSPHP270AUT	2.70	230VAC	2,400 W	Min. 15A/14AWG	50 lbs	30%*

#### PERFORMANCE

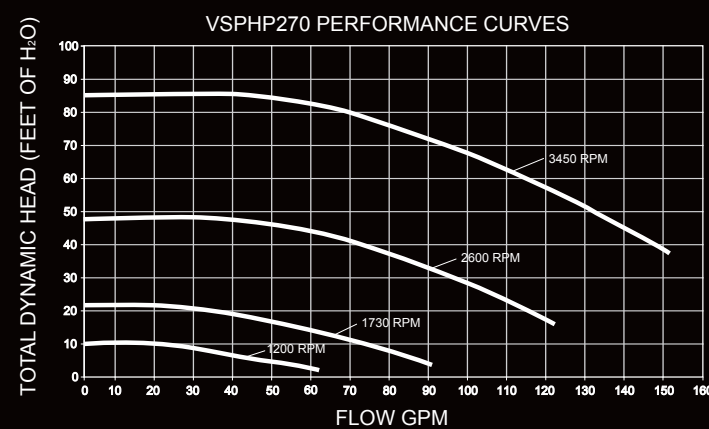

<sup>1</sup> Up to 70% quieter than traditional single-speed pumps. Results based on internal testing.

<sup>2</sup> Actual savings dependent on pump horsepower, usage and energy costs.

<sup>3</sup> Also available without interface, for applications with AquaLink<sup>®</sup> RS, AquaLink PDA, or AquaLink Z4 control systems (VSPHP270AUT).

<sup>4</sup> Always follow local building and safety codes for power requirements and guidelines.

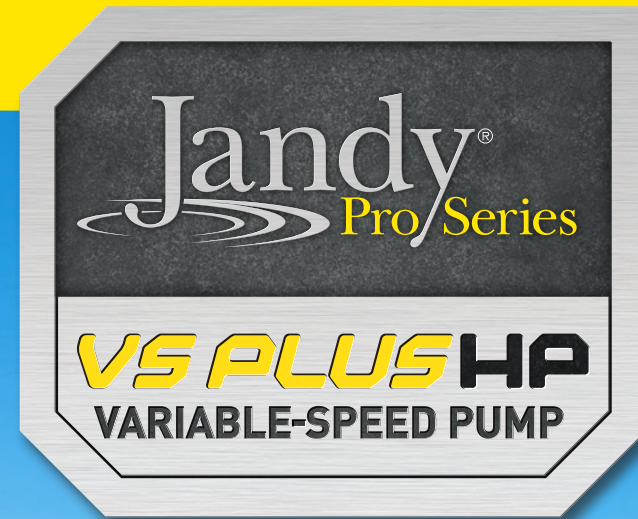

Maximum Efficiency.  
Mid-Sized Wet End.  
Up to 70% Quieter.<sup>1</sup>



© Zodiac Pool Systems, Inc. Not for Internet Resale





## VS PlusHP

- » High Head
- » Mid-Sized Wet End
- » High Efficiency

### UP TO 70% QUIETER

Enjoy the peace and relaxation of your pool without the noise of a traditional pump.



POOL AND SPA COMBOS



SOLAR HEATING



IN-FLOOR SYSTEMS



SHEER DESCENTS



WATER FEATURES



# VS PLUSHP

VARIABLE-SPEED PUMP

## Power Consumption

Jandy Pro Series VS Plus HP versus a single-speed pump.

### VS Plus HP



### Single-Speed Pump



300 Watts

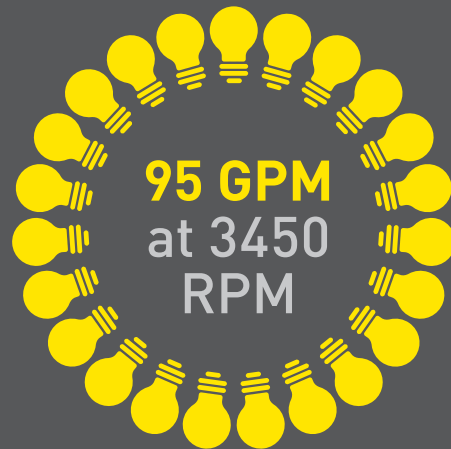

2300 Watts



### SAVE UP TO 90% ON ENERGY COSTS

with the VS PlusHP Variable-Speed Pump.



### AUXILIARY CIRCUIT

Auxiliary circuit can be used to control other devices, such as booster pumps or salt water chlorinators without the need for an additional timeclock.



### MID-SIZED HIGH HEAD VARIABLE-SPEED PUMP

Ideal for pool/spa combos, in-floor cleaning, solar heating systems.



### AUTOMATION OPTIONS AVAILABLE

Model without JEP-R available.

## Size Matters

Small pump baskets fill faster—restricting flow and eroding performance. The VS PlusHP, with its oversized basket, delivers more consistent performance and better efficiency under real-world conditions—with a smaller motor.

VS PlusHP  
2.7 Total  
Horsepower

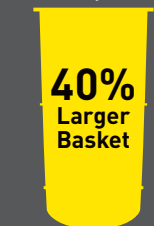

Competitor's  
VS Pump  
3.95 Total  
Horsepower



40%  
Larger  
Basket

Lost flow due to restriction from debris in the pump basket.

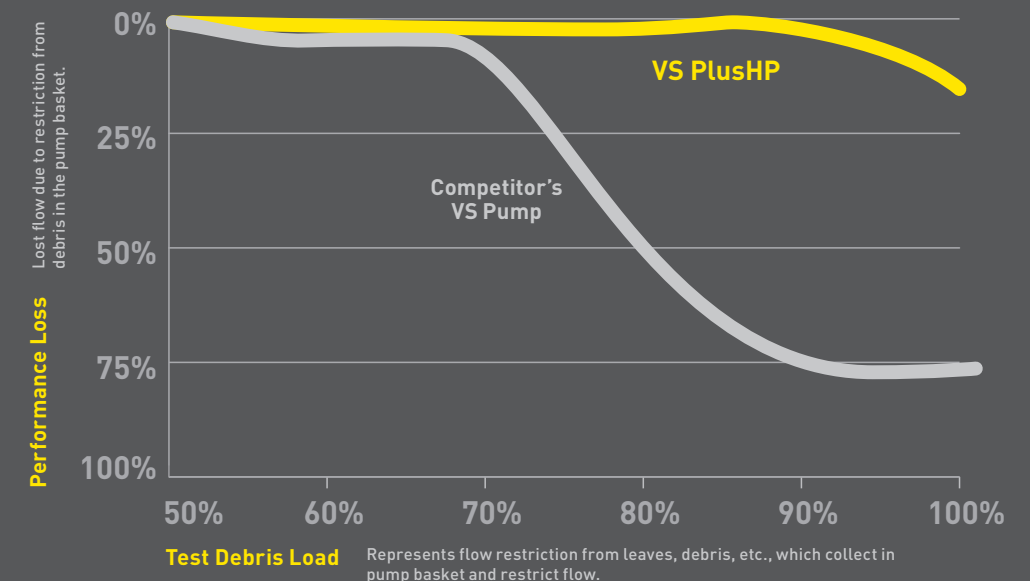

## Standard Features on all Variable-Speed Models

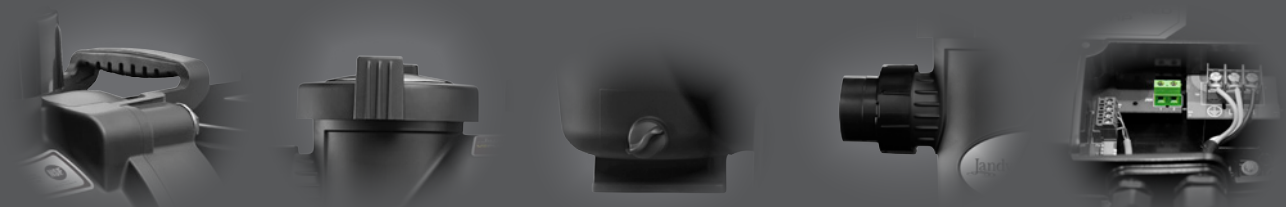

Carry handles for easy installation

Tool-free lids for easy debris removal

Tool-free drain plugs for easy winterization

Unions included, easy installation, no nipples required

Switched aux relay to control another device (2.0 & 2.7 HP motors only)

**GPM:** Gallons Per Minute **RPM:** Revolutions Per Minute 100-Watt Light Bulb

\*Actual energy use dependent on pump speed, usage, and system restriction curve.

Please visit [Jandy.com/energy](http://Jandy.com/energy) to customize your savings.

All Jandy VS pumps meet ENERGY STAR efficiency requirements.

